

Bird's Nest and Jungle Swing

Device line Robinie



Article 40191

Bird's nest and jungle swing made of chemically untreated Robinia heartwood, sanded, suspension device made of stainless steel, corner connectors hot-dip galvanised and additionally lacquered in RAL 7016, with Bird's Nest Huck ø 125 cm, beige rope ring and jungle seat made of 4-sided braided rope, profile 15 x 15 cm.



CHF 7'970.-

(excl. VAT)

	Age group	3+
	Device dimensions	676 x 225 x 275 cm
	Space required	820 x 676 cm
	min. impact surface	33 m ²
	Fall height	199 cm
	Heaviest element	60 kg
	Biggest element	370 x 16 x 16 cm
	Foundations	6
	Concrete	1.2 m ³
	Assembly time	3 h
	Installers	2

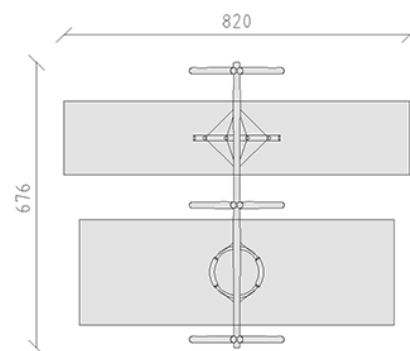

buerli
Center of play