

Swing frame with Bird's Nest

Device line Stahl

Article 62805

Swing frame with bird's nest made of hot-dip galvanised tubular steel, stainless steel suspension devices for two seats, with Bird's Nest Huck \varnothing 125 cm, blue rope ring, minimum installation depth 50 cm.



CHF 4'895.-

(excl. VAT)

	Age group	3+
	Device dimensions	618 x 198 x 269 cm
	Space required	805 x 618 cm
	min. impact surface	42.4 m ²
	Fall height	149 cm
	Heaviest element	50 kg
	Biggest element	315 x 8 x 245 cm
	Foundations	6
	Concrete	1.1 m ³
	Assembly time	3 h
	Installers	2

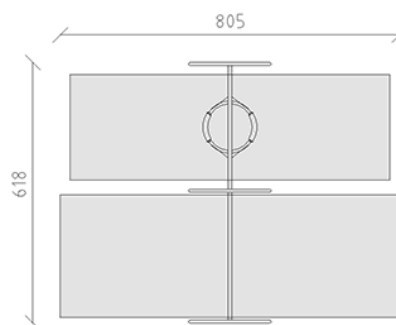

buerli
Center of play