

# Bird's Nest and Jungle Swing

Device line Stahl











Article 62807

Bird's nest and jungle swing made of hot-dip galvanised tubular steel, suspension devices made of stainless steel, with Bird's Nest Huck  $\varnothing$  125 cm, blue rope ring and jungle seat made of square braided rope, 15 x 15 cm, minimum installation depth 50 cm.



**CHF 6'530.-**

(excl. VAT)

 Age group	3+
 Device dimensions	608 x 198 x 269 cm
 Space required	831 x 608 cm
 min. impact surface	33.5 m <sup>2</sup>
 Fall height	202 cm
 Heaviest element	50 kg
 Biggest element	315 x 8 x 245 cm
 Foundations	6
 Concrete	1.1 m <sup>3</sup>
 Assembly time	3 h
 Installers	2

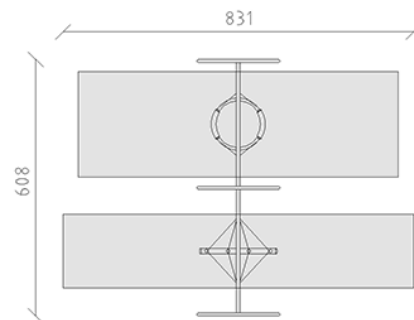

**buerli**  
Center of play

+41 41 925 14 00

info@buerli.swiss